

Newbattle Community High School  
**National 5 Lifeskills**  
Exam Revision Questions  
Printed 03 March 2016

**Exam:** Wednesday 4<sup>th</sup> May 2016

**When to Revise**

- Use this booklet for homework.
- Come to after school revision classes.
- Come to the Easter holiday revision class.
- There will be an immersion revision day before the exam.
- **Also revise AT HOME. A lot.**

**What to use to revise:**

- All the questions from this booklet
- Past Papers (on website or buy from your teacher)
- The revision notes (on website or buy from your teacher)

**How to use these questions:**

Use these questions along with the **revision notes** and the past **paper/model paper** book.

1. Try all the questions in this booklet and the past paper booklet once and check the answers. Ask for help as required.
2. **Put a star next to all the questions you got wrong or required help (from teachers, friends or the notes) with.**
3. Wait a few days and then try the starred questions a second time to see if you can manage them now.
4. If you cannot do them, ask for help again, wait a day or two and then try them again.
5. **Repeat until you can do all the questions without needing help.**

A)	Proportion and Ratio .....	2	O)	Scatter Graphs .....	18
B)	Appreciation/Depreciation ...	3	P)	Scale Drawing .....	19
C)	Analysing Financial Position	3	Q)	Container Packing.....	19
D)	Tax .....	5	R)	Precedence/Task Planning ..	21
E)	Commission and Overtime...	5	S)	Time Zones.....	23
F)	Payslips .....	6	T)	Tolerance .....	23
G)	Best Deal .....	7	U)	Gradient .....	25
H)	Foreign Exchange.....	9	V)	Volumes.....	26
I)	Savings .....	10	W)	Area and Circumference ....	28
J)	Loans and Credit Cards.....	10	X)	Pythagoras .....	29
K)	Probability and Risk.....	13	Y)	Speed, Distance and Time ..	31
L)	Quartiles and Boxplots.....	14	Z)	MIXED TOPICS .....	32
M)	Pie Charts .....	16			
N)	Standard Deviation.....	16			

**A) Proportion and Ratio**

- 1) Non-calculator The ratio of men to women in an office is 5:7. If there are 112 women, how many men work at the factory?
- 2) Non-calculator Billy is a window cleaner. In 45 minutes, Billy cleans 27 windows.
  - a) What is the ratio of minutes to windows? Give your answer in its simplest form.
  - b) If Billy works at the same rate, how long would it take for him to clean 36 windows?
- 3) Non-calculator (2015 exam question) A shop sells Ice Cola in 330 millilitre cans. An individual 330ml can costs 66 pence. Complete the shelf label for Ice Cola below to show the price per litre.

<div style="border: 1px solid black; padding: 5px; margin-bottom: 5px;">330 ml</div> <div style="border: 1px solid black; padding: 5px;">66p</div>	equivalent to	<div style="border: 1px solid black; padding: 5px; margin-bottom: 5px;">1 litre</div> <div style="border: 1px solid black; padding: 5px;">_____</div>
--	---------------	---

- 4) Calculator In a chocolate factory, one machine can make 120 chocolates in 5 minutes. The factory has 12 machines. How long will it take the factory to make 21600 chocolates?
- 5) Non-calculator A factory makes cars. The factory can make 5 cars in 2 hours.
  - a) How many cars can the factory make in 6 hours?
  - b) How long does it take the factory to make 1 car?
  - c) The factory sends its cars out by train. One train can hold 40 cars. How long will it take to make enough cars to fill three trains?

**For further practice on this topic, go to the TeeJay textbook pages 63-71**

**B) Appreciation/Depreciation**

**Success criteria:**

**Mark 1** – correct multiplier

**Mark 2** – correct use of powers

**Mark 3** – correct answer

**Mark 4** – rounding or explanation

- 6) Calculator Zak bought a car for £8500 at the start of a year. Its value depreciated by 8% in the first year and 6% in the second year. Then he sold it. How much did he sell it for? Round your answer to 3 significant figures. (4)
- 7) Calculator It is estimated that house prices will increase at the rate of 3·15% per annum. A house is valued at £134 750. If its value increases at the predicted rate, calculate its value after 3 years. Give your answer correct to four significant figures. (4)
- 8) Calculator There are 2·69 million vehicles in Scotland. It is estimated that this number will increase at a rate of 4% each year. If this estimate is correct, how many vehicles will there be in 3 years' time? Give your answer correct to three significant figures. (4)
- 9) Calculator Jack weighs 94 kilograms. On the 1<sup>st</sup> of January he starts a diet which is designed to reduce his weight by 7% per month. During which month should he achieve his target weight of 73 kilograms? Show all of your working. (4)
- 10) Calculator The temperature in a greenhouse is 30°C. After an hour it has fallen to 28·2°C.
- a) By what percentage has the temperature fallen? (1)
- b) If it continues to fall at the same rate, what will be the temperature after a further four hours? (3)
- 11) Non-calculator Olga normally runs a total distance of 28 miles per week. She decides to increase her distance by 10% a week for the next four weeks. How many miles will she run in the fourth week? Round your answer to 3 significant figures. (4)
- 12) Non-calculator A company buys machinery worth £750 000. The value of the machinery depreciates by 20% per annum. The machinery will be replaced at the end of the year in which its value falls below half its original value. After how many years should the machinery be replaced? You must explain your answer. (4)

**For further practice on this topic, go to the TeeJay textbook pages 32-35**

**C) Analysing Financial Position**

- 13) Non-calculator Anne hired a mobile phone at a fixed charge of £17·50 per month.

She is also charged for her total call time each month. 15 minutes of this total call time are **free**. The rest of her call time is charged at 35 pence per minute.

What is the cost for Anna's phone in a month when her total call time is 42 minutes? (3)

14) Calculator For a charity campaign, 30000 badges must be made. Badges can be bought in boxes of 700. The cost per box depends on the number of boxes ordered:

0-30 boxes	£42 per box
31-40 boxes	£38.20 per box
41-50 boxes	£34.60 per box
50+ boxes	£28 per box

If the badges are sold for 60p each, how much profit will the charity make if all the badges are sold? (4)

15) Calculator Mrs Johnson's monthly income is £2275. She works out her monthly expenditure as follows:

Category	Percentage
Food	27%
Mortgage	32%
Entertainment	8%
Utilities	24%
Car	2%

- How much does Mrs Johnson spend on utilities each month? (2)
- What is the ratio of the amount Mrs Johnson spends on her mortgage to the amount she spends on utilities? Give your answer in its simplest form. (2)
- Mrs Johnson puts all her left-over money into a savings account each month. How much money is this? (3)
- Mrs Johnson decides she needs to save more, so she reduces all of her expenses, **except her mortgage and utilities** by 5% each month. How much will she save now? (3)

16) Calculator Gary is a carpenter who makes wardrobes. The table below shows the cost of materials required to make 5 wardrobes.

<b>Cost of materials</b>	
<i>Makes FIVE wardrobes</i>	
Oak wood (doors)	£140
Pine wood (sides)	£80
Hinges	£17
Handles	£38
Plastic shelving	£29

- What percentage of the total cost is spent on wood? (3)
- Gary makes 20 wardrobes. He wants to make a profit of £2000. What price should he sell each wardrobe for? (4)

**For further practice on this topic, go to the green textbook pages 175-178 (Exercises 9.1A and 9.1B)**

**D) Tax****Current UK Tax Rates:**

Taxable income (£)	Rate
On the first £31 865	20%
Over £31 865 and up to £150 000	40%
Over £150 000	45%

- 17) Calculator Alexandra earns £26 745 a year. Her tax allowances total £9650. Using the table of current UK tax rates above, calculate Alexandra's annual salary after tax is deducted. (3)
- 18) Calculator Sandra earns £3256 a **month**. Her **annual** tax allowances total £8590. Using the table of current UK tax rates above, calculate her:
- annual** tax bill. (3)
  - monthly** take home pay. (2)
- 19) Calculator John earns £62 000 per year. His annual tax allowances are £7650. Using the table of current UK tax rates above, calculate John's annual tax bill. (4)
- 20) Calculator Anna earns £47 000 per year. She has tax allowances of £10425. The rates of tax applicable for the year are given in the table below:

Taxable income (£)	Rate
On the first £34 600	20%
On any income over £34 600	40%

How much is Anna's **monthly** tax bill? (5)

**For further practice on this topic, go to the TeeJay textbook pages 203-204**

**E) Commission and Overtime**

- 21) Non-calculator Stephen plans to go to a concert. The ticket costs £49.00. He works 2 hours overtime on Friday night at time and a half, and 2½ hours overtime on Saturday morning at double time. If his basic pay is £6.80 per hour, will his overtime pay cover the cost of the ticket? Explain your answer. (4)
- 22) Non-calculator Joseph works as a childminder. He is paid at a rate of £8.10 per hour for weekdays and time and a half for weekends. One week he works from 9am until 1pm every day except Sunday. Calculate Joseph's gross pay for the week. (4)
- 23) Calculator Ali is paid a basic annual salary of £8500 plus commission on his sales as shown in the table below:

Sales	Rate of commission on sales
Less than £25 000	1.5%
£25 000 to £50 000	1.75%
More than £50 000	2.0%

- a) If Ali achieves sales of £24 900, what will his total annual salary be? (2)
- b) What would Ali's sales need to be to achieve a total annual salary of £9600? (4)

24) Calculator Irene works in the local chemist's shop. One week she works 40 hours at her basic rate of pay and 3 hours overtime at double time.  
Her gross pay for that week was £239.20. Calculate Irene's basic hourly rate of pay. (3)

**For further practice on this topic, go to the green textbook pages 4 and 5 (Exercise 1.1B) or TeeJay textbook pages 197-199**

**F) Payslips**

- 25) Calculator Tony earns £35400 a year.
- a) Tony's tax allowances total £8460 and he pays all his tax at a rate of 20% on his taxable income. Calculate Tony's annual tax bill. (3)
  - b) Tony pays 8.6% National Insurance on income over £7640. Calculate his annual National Insurance bill. (3)
  - c) Calculate Tony's net monthly pay. (2)
- 26) Calculator Andy works for Company A and is paid £1350 per month plus 5% commission on sales over £25000.

His partner Jack works for Company B and is paid £1520 per month plus 3.5% commission on sales over £22000.

In June they both had sales of £50 000. Who earned more in total, and by how much? (4)

27) Non-calculator Erica works as a masseuse at a health club. Her March payslip, shown below, is only partly completed. Erica is paid a bonus of £7.25 for each massage she completes.

During March Erica does 88 massages. She also pays 6% of her gross monthly pay into her pension. Calculate Erica's net pay for March. (3)

<b>Name</b> E. Roe	<b>Employee No.</b> 666	<b>Tax Code</b> 710L	<b>Month</b> March
<b>Basic Pay</b> £1350	<b>Overtime Pay</b> -	<b>Bonus</b>	<b>Gross Pay</b>
<b>Nat. Insurance</b> £187.42	<b>Income Tax</b> £297.59	<b>Pension</b>	<b>Deductions</b>
			<b>Net Pay</b>

28) Calculator A copy of Logan Pollock’s payslip is shown below for one week in February.

<b>Name</b> L. Pollock	<b>Employee No.</b> 027	<b>Tax Code</b> 64L	<b>Week Ending</b> 14/02/2012
<b>Basic Pay</b> £296.00	<b>Overtime Pay</b> £55.50	<b>Bonus</b> —	<b>Gross Pay</b> £351.50
<b>National Insurance</b>	<b>Income Tax</b> £45.40	<b>Pension</b> £21.09	<b>Deductions</b>
			<b>Net Pay</b>

Logan worked 40 hours for his basic pay.

- If overtime was paid at the rate of “time and a half”, calculate how many hours of overtime he worked during that week. (3)
- Logan pays 12% National Insurance on all weekly gross pay over £310. Calculate Logan’s National Insurance, Deductions and Net Pay. (4)

29) Calculator Anne Ibbotson works for a computer software company. Her March salary slip, shown below, is partly completed.

<b>Name</b> A. Ibbotson	<b>Employee No.</b> 01987623	<b>N.I. No.</b> YT91875F	<b>Tax Code</b> 443L	<b>Month</b> March
<b>Basic Salary</b> £2000	<b>Commission</b>	<b>Overtime</b> Nil	<b>Gross Salary</b>	
<b>Nat. Insurance</b> £158.00	<b>Income Tax</b> £421.21	<b>Pension</b>	<b>Total Deductions</b>	
			<b>Net Salary</b>	

Anne is paid a basic monthly salary of £2000 plus commission of 12% of her total monthly sales. 6% of Anne’s gross monthly salary is paid into her pension fund.

Calculate Anne’s net salary for March, when her sales totalled £3398. (4)

30) Calculator Jack works a basic week of 35 hours. Any overtime is paid at time and a half. One week he works for 39 hours and is paid £255.84. How much is he paid for each hour of overtime?

**For further practice on this topic, go to the TeeJay textbook pages 200-202**

**G) Best Deal**

31) Calculator TV World has a price promise:

*If you can find the same products cheaper anywhere else, we will refund the **difference plus an extra 40%***

## National 5 Lifeskills Maths Exam Revision Questions

Here are the prices and offers on a selection of goods at TV World and the two other nearby electronics stores:

	TV World	McDonald's AV	TechCentre
Tablet	£169.99	£154.99	£172.99*
Sound System	£140	£140	£165.49*
Headphones	£74.99	£97.99	£69.99*
Laptop	£650	£625	£600
Plasma TV	£299.99	£289.99	£279.99

McDonald's AV has a sale offering **15% off** all items that cost more than £250.

TechCentre is offering **one-third off** all the starred (\*) items in a sale.

- (a) How much would it cost Jackie to buy headphones, a laptop and plasma TV from each of the three shops? **(3)**
- (b) If Jackie buys the headphones, laptop and plasma TV from TV World, will she be entitled to any money back on TV World price promise? If so, what is the maximum amount of money she can expect to get back? **(2)**

32) Non-calculator To use a Fun Park you can either buy:

- Unlimited ride wristbands or
- A Fun Park Pass and single tokens

The prices are given below:

Price List	
Individual unlimited ride wristband	£36
Family of four unlimited ride wristband	£95
Fun Park pass per person	£6
Single tokens (each)	£2

Ride	Number of Tokens Required
Ghost Train	3
Dodgems	2
Zero Gravity	6
Flying Rockets	2
White Water Ride	4
Big Splash Mountain	4

The Chung family consist of 2 adults and 2 children.

- a) Calculate how much it would cost the Chung family to buy Fun Park passes and enough single tokens for each of them to go once on Zero Gravity, White Water Ride and Big Splash Mountain. **(2)**
- b) The Chung family thinks that buying Fun Park passes and single tokens is the cheapest way to go on these three rides. Is the Chung family correct? **(2)**
- c) The Chung family wants to return next week to go on ALL of the rides once. What will be the cheapest way for them to do this? Show your working. **(4)**



33) Calculator Alan takes his 3 children to the cinema every Saturday afternoon. Adult tickets cost £9.15 and child tickets cost £5.35.

<b>Gold Monthly Family Ticket. Cost £25.</b>	<b>Platinum Monthly Family Ticket. Cost £15.</b>
40% off <u>all</u> ticket prices	Adults pay full price.
Once you've bought more than 12 tickets in a month, any further tickets are free	65% off all children's tickets

In May 2015 there are five Saturdays. Alan has three options:

- Buy all tickets full price
- Buy a Gold Family Ticket to try and save money.
- Buy a Platinum Family Ticket to try and save money.

Which option is cheapest for Alan and by how much? (5)

34) Non-calculator Helen is posting a parcel weighing 6kg. She has a choice of three companies:

Royal Post: £8.50 + 75p per ½kg

MailFast: £6.80 + £1.90 per kg

RailMail: £4.50 per kg, with a 10% discount

Which company is the cheapest for Helen to post her parcel?

**For further practice on this topic, go to the textbook pages 81-82 (Exercise 4.5B)**

## H) Foreign Exchange

35) Non-calculator Julie booked a holiday to Austria and changes £2300 into Euros. She booked the holiday in May when the exchange rate for Euros in May was £1 = 1.6348 Euros but she waited until June to change her money into Euros, when the exchange rate was only £1 = 1.5219 Euros. How much money did Julie lose by waiting a month?

36) Calculator The exchange rates for some currencies are shown in a table on the right.

<b>Exchange Rates £1 buys</b>	
Japanese Yen (¥)	172.419
Euros (€)	1.2666
US Dollars (\$)	1.6054
Swedish Krona (kr)	11.5082
Indian Rupee (₹)	97.9293
Korean Won (₩)	1712.97

Mr and Mrs Kwon fly on Oceanic Flight 815 from South Korea to the UK for a six night stay. They bring 4 000 000 Korean Won with them, which they change into pounds.

Whilst in the UK, they spend £125.80 **per night** for a hotel stay, £30 **per person** for entry to London Zoo, £45 **per ticket** for two tickets on the London Eye, £384 **in total** on shopping and £278.50 **in total** on food.

Before their return flight, they change their remaining money back into Korean Won. How many Won do they get? (5)

37) Calculator Martin is buying a Volvo car.

- A Volvo car bought in the **UK** costs £9254 plus 2·5% tax.
- A Volvo car bought in **Sweden** costs 94800kr plus an extra 2650kr to ship it to the UK.

Using the exchange rate table from the previous question, is it cheaper for Martin to buy the Volvo in the UK or in Sweden? How much cheaper? (5)

38) Non-calculator June goes on a business trip to New York and Rio de Janeiro. She takes £6000 with her which she changes to US Dollars. Using the exchange rate table from the previous question:

- a) Calculate how many US Dollars June will receive. (2)
- b) June spends \$3432·40 in the USA, and then changes all her money into Brazilian Real. The exchange rate is **1 real = \$8**. How much Brazilian currency does she receive? (3)
- c) June spends 200 real in Brazil and then changes her money back into pounds. The exchange rate is **£1 = 1·25 real**. How many pounds does June get back? (3)

**For further practice on this topic, go to the TeeJay textbook pages 214-216**

#### **I) Savings**

39) Non-calculator Dave puts £4500 into a bank account with an interest rate of 2½% per annum. At the end of the year he gets paid interest and he takes £2800 out of the account. What is the account balance after this? (4)

40) Calculator Jenny puts £7400 into a bank account with an interest rate of 1·85% per annum. What is the balance in the account after 5 years? Round your answer to four significant figures (4)

41) Calculator Hannah puts £60 000 into the bank. After one year's interest is added, she has £61 650.

- a) What must the annual rate of interest have been? (1)
- b) If the rate of interest stays the same, and if Hannah doesn't take any money out of the account, how much will she have after a **further** three years? (4)

42) Calculator Amanda put £6500 into a bank account. She was paid interest of 1·3% p.a. for four years and then interest of 2·5% p.a. for two years. Find:

- a) the total interest for the six years.
- b) the tax paid on the interest if tax is paid at 20%.

#### **J) Loans and Credit Cards**

43) Calculator Dawn has a credit card with a (compound) monthly interest rate of 3·285%. Her current balance is £1576·45. If Dawn does not pay off any of the balance, how much will she owe after one year? (4)

44) Calculator Andrew takes out a loan of £12000 for a car at a **simple** interest rate of 13·4% per annum, which he will pay back in 36 equal monthly instalments. What is Andrew's monthly instalment? (3)

- 45) Calculator Anne has to repay a loan of £9000 that has a **simple** interest rate of 31% p.a., which she will pay back in equal monthly amounts. How much more will she pay per month if she pays back over 1 year rather than 2 years?
- 46) Calculator Jack takes out a loan of £5000. After one month's interest has been added, he owes £5175.
- What must the monthly rate of interest per month have been? (1)
  - If the rate of interest stays the same, and if Jack pays no money back, how much will he owe after a **further** four months? (3)
- 47) Non-calculator The table below gives the monthly repayments from three different banks on a £10000 loan repaid over five years.

Name of Bank	Monthly Repayments	
	With payment protection	Without payment protection
Savewell	£245.39	£214.39
Finesave	£260.58	£205.65
Wisepend	£263.17	£214.70

Emily borrowed £10 000 and paid it back over five years. The cost of the loan was £2339. Which bank was the loan from and did she take it with or without payment protection? (3)

- 48) Non-calculator Simone's balance on her credit card statement was £600. Her minimum payment is £20 or 3.2% of her balance, whichever is the greater. What is her minimum payment? Show all of your working. (2)
- 49) Calculator Sam's credit card company charges 3.7% interest per month on the balance at the end of a month.

On the 1<sup>st</sup> April 2014, Sam owes £2570. He cuts his card up and makes regular monthly payments of £260 on the last day each month (starting 30<sup>th</sup> April) to clear the debt.

How much money does Sam owe on the 1<sup>st</sup> July 2014? (3)

- 50) Calculator Part of Wendy's credit card statement is shown on the right.

The interest charged is 18.6% of the balance from the previous statement. The minimum repayment is 2.5% of the Total Balance or £5, whichever is greater.

- Calculate the values of A, B and C.
- If Wendy makes the minimum repayment, how much interest will be charged the next month? (3)

Credit Limit = <b>£1000</b>	
Balance from previous statement	£25.78
Interest	£A
Cliff Petrol Station	£36.45
Save More Supermarket	£64.17
H R Brown	£13.25
Total Balance	£B
Minimum repayment	£C
<b>Minimum repayment = 2.5% of balance or £5, whichever is greater</b>	

- 51) Non-calculator Below is the summary part of Geetha's Credit Card statement at the end of May. If Geetha makes the minimum payment, and does not use the credit card again, what will be the "Balance Owed" in the next statement? (2)

<b>CREDIT CARD STATEMENT</b>	
Summary as at 21 <sup>st</sup> May 2015	
Credit Limit	£4000
Available Credit	£3760
Balance from previous statement	£0.00
New Transactions	£240.00
Interest	£0.00
Balance owed	£240.00
Minimum payment due	£7.20
Payment due date	15 <sup>th</sup> June 2015
Interest will be charged at 2% per month on any outstanding balance.	

- 52) Non-calculator Below is a copy of part of David Leblanc's credit card statement.

<i>Southern Star Credit</i>		
Name: David Leblanc		12 May, 2008
Card Number: 4517 6767 2368 9001		Credit Limit £3600
12 April 2008	Balance brought forward	£125.00
2 May 2008	Payment received	<u>-50.00</u>
	Balance	<b>A</b>
	Interest at 1.6%	<b>B</b>
5 May 2008	Bon Cave Wines	62.99
5 May 2008	Jacques Delicatessen	15.88
	Balance owed	<b>C</b>
Minimum payment: 3% of Balance owed or £5, whichever is greater.		

- a) Calculate the amounts which would appear at A, B and C. (3)  
 b) David makes the minimum payment. How much does he pay? (2)

**For further practice on this topic, go to the textbook pages 77-79 (Exercises 4.4A and 4.4B)**

**K) Probability and Risk****Success criteria:****Mark 1** – write probability as a fraction, decimal or percentage (not a ratio)**Mark 2** – express probability in its simplest form53) Calculator 150 patients have been given a flu vaccine.

The data is shown in the table below.

Age	Gender	
	Male	Female
5 or under	4	3
6 – 15	7	8
16 – 59	37	47
60 or over	12	32

- (a) What is the probability that:
- a patient given the flu vaccine was male and aged 60 or over? **(2)**
  - a patient given the flu vaccine was aged 5 or under? **(1)**
- (b) If there were 340 people to vaccinate, how many under 5 year old males would you expect? **(2)**
- (c) What is the ratio of males to females in its simplest form? **(2)**

54) Non-calculator As part of a game, two normal, fair dice are rolled.

- a) Complete this table to show all the possible outcomes:
- (1)**

		Die 2					
		1	2	3	4	5	6
Die 1	1	1, 1	1, 2	1, 3			
	2	2, 1	2, 2				2, 6
	3	3, 1					3, 6
	4						4, 6
	5						5, 6
	6	6, 1	6, 2	6, 3	6, 4	6, 5	6, 6

- b) What is the probability of rolling a 5 and a 5? **(1)**
- c) What is the probability that the two dice will show a total of 9? **(2)**

55) Non-calculator Michelle is practicing her penalty kicks.Last week, Michelle scored 18 out of 30. This week, she scored 16 out of 25. Has her scoring rate improved? **Explain your answer. (2)**

56) Non-calculator The table on the next page shows the medals won by three countries in an Asian athletics tournament:

	Gold	Silver	Bronze
Japan	5	8	11
Thailand	1	4	5
Pakistan	2	1	3

- One of Japan's medals is picked at random. What is the probability that it is a gold medal? **(1)**
- One of the gold medals is picked at random. What is the probability that it belongs to Japan? **(1)**
- Which event is more likely: (a) or (b)? **Explain your answer. (1)**

57) Calculator The table below shows the number of S5 Boys and Girls choosing to study different Higher subjects at Newbyres High School.

	Boys	Girls
Biology	56	26
History	37	32
Engineering	12	8
Philosophy	47	31

Are boys more likely to study engineering than girls? **Explain your answer. (3)**

58) Non-calculator Karen orders a mobile phone from Phones-R-Us. Phones come in 5 colours: silver, black, dark blue, light blue, pink. Phones come in three brands: modern, classic, cyber. Karen gets sent a phone at random.

- Complete this table to show all the possible options Karen could get: **(1)**

		Colour of Phone				
		Silver	Black	Dark Blue	Light Blue	Pink
Brand of Phone	Modern	Modern Silver	Modern Black	Modern Dark Blue		
	Classic	Classic Silver				
	Cyber					Cyber Pink

- Karen really wants a classic phone in a shade of blue. What is the probability she will get one? **(1)**

**For further practice on this topic, go to the TeeJay textbook pages 98-100 and 259-262 or the green textbook page 231 (Exercises 11·4B)**

## L) Quartiles and Boxplots

**Success criteria for comments:****Mark 1** – valid comment relating to the median**Mark 2** – valid comment relating to more varied/more consistent

59) Non-calculator The temperatures, in degrees Celsius, at noon for the first ten days in January at Invergow were:

–3 0 –2 2 –1 –4 –5 3 1 3

- Draw a boxplot to show these temperatures. **(4)**
- Calculate the semi-interquartile range. **(1)**
- At 8am on the same days, the median temperature was  $-1.5^{\circ}\text{C}$  and the semi-interquartile range was  $5^{\circ}\text{C}$ . Make two comments comparing the temperatures at 8am and noon in Invergow. **(2)**

*Show your sentences to a teacher so they can tell you whether your sentences would have been awarded the marks.*

60) Non-calculator Janet is a driving instructor. She looks at her diary for the next 30 days and writes down the number of tests booked for each day as shown below:

<i>Number of tests booked</i>	0	1	2	3	4	5	6
<i>Frequency</i>	1	1	3	2	9	10	4

- Make a five-figure summary and calculate the inter-quartile range. **(4)**
- On one day chosen at random, Janet is ill. If she has more than four tests booked, they will have to be cancelled. Find the probability that Janet's tests must be cancelled. **(2)**
- Gregor is another driving instructor. His median number of tests booked is 5 and his inter-quartile range is 4. Make two comments comparing the number of tests booked for Janet and for Gregor. **(2)**

*Show your sentences to a teacher so they can tell you whether your sentences would have been awarded the marks.*

61) Non-calculator Sandi takes the bus to work each day. Over a two week period she records the number of minutes the bus is late each day. The results are shown below.

5 6 15 0 6 11 2 9 8 7

- For the above data, find the median and the inter-quartile range **(4)**
- Construct a boxplot for the data **(2)**

Sandi takes the train over the next two week period and records the number of minutes the train is late each day. The boxplot drawn below is constructed for the new data.

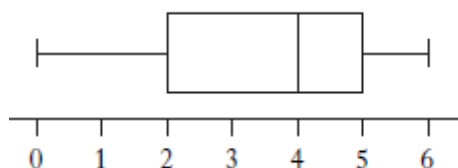

- Compare the two boxplots and comment. **(2)**

*Show your sentences to a teacher so they can tell you whether your sentences would have been awarded the marks.*

- 62) Non-calculator A company that manufactures shoelaces spot check the length (in cm) of their 27cm laces. Here are the results for two different production lines.

<b>Line A</b>	26.8	27.0	26.5	27.0	27.3	27.5	26.1	26.4	27.9	27.3
<b>Line B</b>	26.8	26.7	27.1	27.0	26.9	27.0	27.3	26.9	27.0	27.3

Draw a box plot for line A and line B. Which is the better production line? **Give a reason for your answer. (5)**

**For further practice on this topic, go to the TeeJay textbook pages 243-245**

### M) Pie Charts

**Success criteria:**

**Mark 1** – angles calculated correctly

**Mark 2** – pie chart drawn with all angles drawn correct to 2°

**Mark 3** – pie chart complete and labelled

- 63) Non-calculator A sample of voters was asked how they intended to vote at the next election. The responses are shown in the table on the right.

<i>Party</i>	<i>Percentage</i>
Scottish National Party (SNP)	35%
Labour (Lab)	30%
Liberal Democrat (Lib Dem)	15%
Conservative (Con)	10%
Others	10%

Construct a pie chart to illustrate this information. Show all of your working. **(3)**

- 64) Calculator The favourite soap of 480 children are given in the table. Draw a pie chart to show this information. Show all of your working. **(3)**

<i>Soap</i>	<i>Number of people</i>
Hollyoaks	266
Coronation Street	66
EastEnders	90
Emmerdale	30
Other	28

### N) Standard Deviation

**Success criteria for calculating standard deviation:**

Mark 1 – calculate mean

Mark 2 – subtract, square, add

Mark 3 – divide by  $n - 1$  and square root

Mark 4 – calculate correctly

**Success criteria for comments:**

Mark 1 – valid comment relating to the mean

Mark 2 – valid comment relating to more varied/more consistent

- 65) Non-calculator A group of people attended a course to help them stop smoking. The following table shows the statistics before and after the course.



	<i>Mean number of cigarettes smoked per person per day</i>	<i>Standard deviation</i>
Before	20·8	8·5
After	9·6	12·0

Make two valid comments about these results. **(2)**

*Show your sentences to a teacher so they can tell you whether your sentences would have been awarded the marks.*

66) Calculator A ten-pin bowling team recorded the following six scores in a match

134 102 127 98 104 131

- For this sample calculate the mean and the standard deviation. **(4)**
- In their second match the six scores have a mean of 116 and a standard deviation of 12·2. Were the team's scores more consistent in the second match? Explain your answer. **(1)**

67) Calculator Harry often plays golf and the scores for some of his games are recorded below:

84 78 87 80 81

- For this sample, calculate the mean and the standard deviation. **(4)**
- His partner for these games is Tony, whose scores are listed below:

104 98 107 100 101

Write down the mean and standard deviation of Tony's scores. **Do not calculate them using the formula.** **(2)**

68) Calculator A sample of six boxes contains the following number of pins per box:

43 39 41 40 39 44

- For the above data, calculate the mean and standard deviation. **(4)**

The company which produces the pins claims that “the mean number of pins per box is  $40 \pm 2$  and the standard deviation is less than 3”.

- Does the data in part (a) support the claim made by the company? Give reasons to support your answer. **(2)**

**For further practice on this topic, go to the TeeJay textbook pages 248-249**

**O) Scatter Graphs****Success criteria:****Mark 1** – axes correct**Mark 2** – half of points plotted correctly**Mark 3** – all points plotted correctly

69) Calculator Brunel plc has a fleet of delivery vans. Each van costs a different amount to maintain. The company wants to set up a forecasting system which will allow them to estimate how much it will cost to maintain their vans

Van	A	B	C	D	E	F	G	H	I	J	K
Age (months)	63	13	34	40	80	51	14	45	74	24	82
Maintenance cost (£ per month)	141	14	43	70	170	95	21	72	152	31	171

- The company plans to replace any van that costs more than £1800 per year to maintain. What percentage of the company's vans need to be replaced? **(3)**
- Use this data draw a Scatter Graph. **(3)**
- Draw a best-fitting line on the graph. **(1)**
- Estimate from your line the maintenance cost for a vehicle aged 60 months. **(1)**

70) Non-calculator There was a vacancy for a admin assistant typing letters at BetterPrint. Seven people applied for the job. The manager gave each applicant a test **before practice**, which consisted of typing a page of writing. Marks were awarded for the speed and for the accuracy of the typing. The following table shows the results of the test:

Applicant	A	B	C	D	E	F	G
Time to complete (seconds)	56	44	60	50	80	30	23
Number of errors	3	4	2	4	1	7	6

- Using these marks draw a Scatter Graph. **(3)**
- Draw a best-fitting line on the graph. **(1)**
- Estimate the number of mistakes made by a typist who took 40 seconds to complete the test. **(1)**

The manager gave the seven applicants some time to practice before they came back and re-did the test. Six of the results **after practice** are shown in the table below:

Applicant	A	B	C	D	E	F
Time to complete (seconds)	50	30	60	50	20	40
Number of errors	1	3	0	0	4	2

- On the **same diagram**, draw a second scatter graph and a second line of best fit for the second set of data. **(3)**
- Applicant H took the test once. She took 45 seconds and made 4 mistakes. Is she more likely to have done the test before practice or after practice? **Explain your answer.** **(2)**

**For further practice on this topic, go to the TeeJay textbook page 256**

**P) Scale Drawing**

71) Calculator The diagram shows the position of three airports, Aberdeen (A), Edinburgh (E) and Glasgow (G).

Glasgow is 200km from Aberdeen. Edinburgh is 160km from Aberdeen.  
 From Glasgow the bearing of Aberdeen is  $052^\circ$ .  
 From Aberdeen the bearing of Edinburgh is  $216^\circ$ .

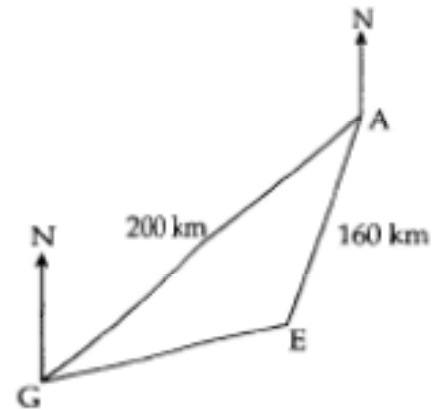

Choose a suitable scale and construct a scale drawing and use it to calculate the distance between Glasgow and Edinburgh airports. (6)

72) Calculator Oakland High School's orientation championships involves a navigation course which is planned as follows:

- Start at checkpoint 1.
  - Travel 10 minutes at a speed of 8.5 metres per minute on a bearing of  $150^\circ$  to checkpoint 2.
  - Travel 12 minutes at a speed of 75 metres per minute on a bearing of  $015^\circ$  to checkpoint 3.
  - Return to checkpoint 1.
- a) Choose an appropriate scale and construct a scale diagram of the course. (5)  
 b) The current record time for Oakland High School's Orientation Championships is 9 minutes. Rob's team complete the entire course at an average speed of 16km/h. Did Rob's team break the record? (3)

73) Calculator Zoe is finding the height of a building.

As shown in the diagram, points A and B are 50 metres apart and Point C is at the top of the building.

The angle of elevation of point C is  $40^\circ$  from Point A and  $65^\circ$  from Point B as shown in the diagram.

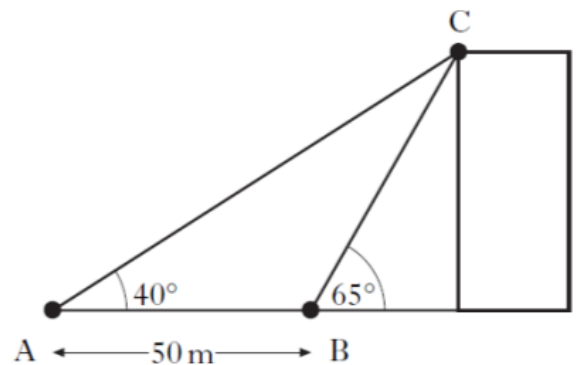

Choose an appropriate scale and use it to make a scale drawing of this diagram and use it to find the actual height of the building. (5)

**For further practice on this topic, go to the TeeJay textbook page 130-131**

**Q) Container Packing**

- Success criteria:** (I'm guessing a bit here, as this has never been asked in an exam before)
- Mark 1** – identify all combinations of ways of packing the containers  
**Mark 2** – know how to divide  
**Mark 3** – round down to nearest whole number and calculate totals  
**Mark 4** – identify maximum (and, if asked, identify how they should be packed)

- 74) Calculator A company makes gadgets that are packed in small boxes. Each small box measures 85cm by 60cm by 90cm as shown in the diagram. The gadgets must be packed upright.

The gadgets need to be packed into large boxes measuring 3 metres by 4 metres by 5 metres.

- a) What is the **maximum** number of gadgets that can be packed into each large box? Show working to justify your answer. (4)

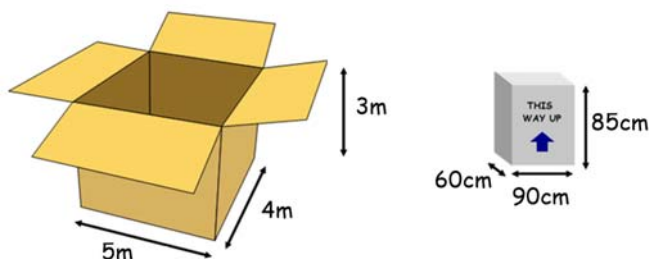

- b) The company have 320 gadgets to be transported. If they pack the maximum number in each large box, how many large boxes will they need? (2)

- 75) Non-calculator Tins of beans have to be packed into a larger box. Each tin of beans is a cylinder with diameter 6cm and height 10cm.

The larger boxes are cuboids measuring 50cm by 30cm by 40cm.

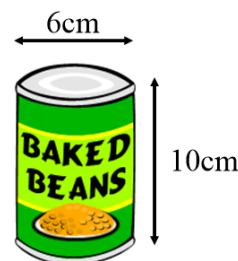

What is the maximum number of tins that can be fitted into one box, and how should they be packed to allow this to happen? [**Hint** – there are three ways that they can be packed] (4)

- 76) Non-calculator A company makes boxes of rubbers for classrooms. Each rubber is a cuboid measuring 2cm by 1cm by 2.5cm.

The rubbers are packed into larger boxes measuring 5cm by 10cm by 2cm.

What is the maximum number of rubbers that can be fitted into one box, and how should they be packed to allow this to happen? [**Hint** – there are four ways that they can be packed] (4)

- 77) Non-calculator A large box is filled with packets of rice. Each packet measures 15cm by 6cm by 22cm and the packets must be stacked upright in the box.

- a) What is the largest number of packets that can be fitted into **bottom layer** of the box? (2)
- b) The full box contains 150 packets with no room left at the top. What is the height of the box? (3)
- c) How many large boxes can be stacked on top of each other in a warehouse that is 5 metres high? (2)

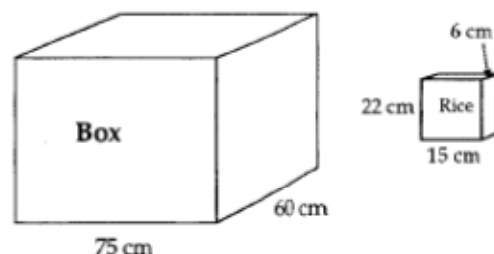

**For further practice on this topic, go to the TeeJay textbook page 165-167**

**R) Precedence/Task Planning**

78) Non-calculator The Clarks employ Kitease to install a new kitchen for them. Kitease provide a team of workers to install the kitchen. The table shows the list of tasks and the time required for each.

Task	Detail	Preceding Task	Time (hours)
A	Begin electrics	None	3
B	Build cupboards	None	5
C	Begin plumbing	None	2
D	Plaster walls	A, B, C	8
E	Fit wall cupboards	D	6
F	Fit floor cupboards	D	5
G	Fit worktops	F	3
H	Finish plumbing	G	3
I	Finish electrics	E, G	4

a) Complete the diagram below by inserting the tasks and times into each box. (2)

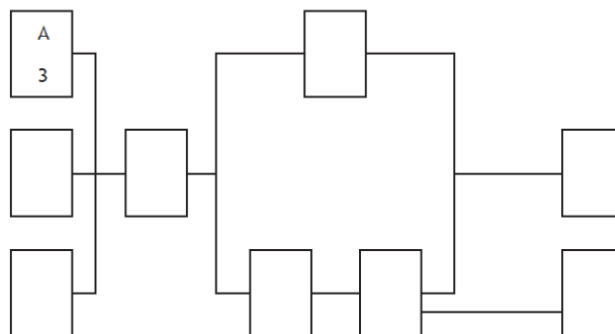

b) Kitease claim they can fit the kitchen in 22 hours. Is this a valid claim? (2)

79) Non-calculator Three friends decide to tidy up their garden. The tasks which need to be done are shown in the table below:

Task	Detail	Preceding Task	Time (minutes)
A	Clear rubbish from garden	None	10
B	Get lawnmower and edge shears from shed	None	5
C	Get hedge trimmer from shed	None	5
D	Cut grass in garden	A, B	30
E	Trim edges of lawn	B, D	10
F	Cut the hedge	C	20
G	Put grass clipping in bag	D, E	5
H	Put hedge clippings in bag	F	5
I	Take bags to recycling centre	G, H	45

a) Fill the tasks and times in the diagram on the next page. (2)

- b) Calculate how much time the friends should allow in total for the task to be completed. (2)

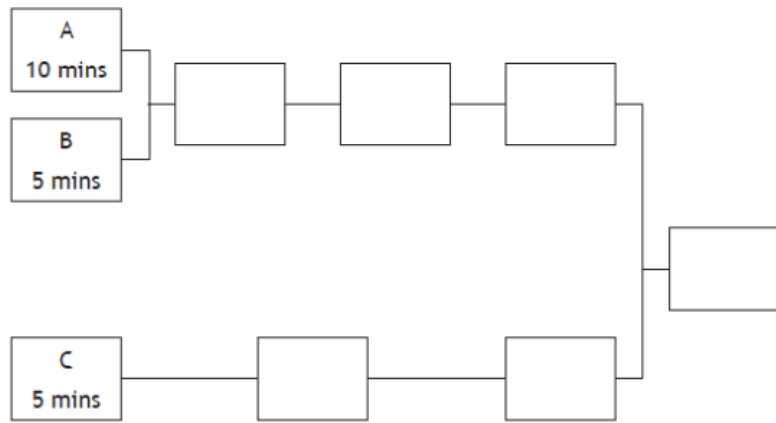

- 80) Non-calculator Jane is preparing a meal for her friends. She has the following list of instructions, but they are not in order.

Task	To Do	Preceding Task	Time length (minutes)
A	Prepare the vegetables	B	20
B	Go to the shops and collect the ingredients	None	30
C	Set the table	D, E	10
D	Boil the vegetables	B, G	30
E	Cook the chicken	B, G	45
F	Serve the meal	C	10
G	Prepare the chicken	A	15

- (a) Write the instructions and times into the correct places in the diagram below. (2)

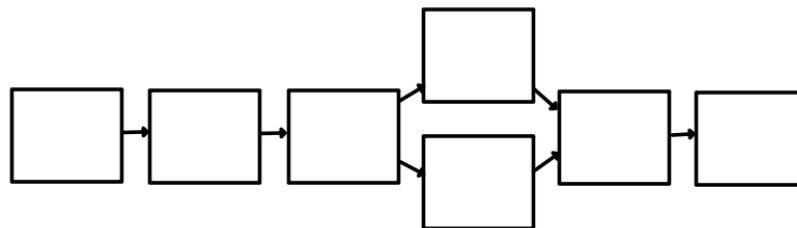

- (b) Jane is due to finish serving the meal at 1835. What is the **latest** possible time Jane must start the job? (3)

- 81) Non-calculator To lay a pipe workmen need to do the following tasks. Some of the tasks can be carried out at the same time:

Task	To Do	Preceding Task	Time (hours)
T	Fill the trench	W, X	1
U	Dig Trench	Y	3
V	Lay 1 <sup>st</sup> lengths	U, Z	1
W	Lay the rest of the pipes	V	2
X	Make joins	V	3
Y	Prepare the area	None	1
Z	Deliver Pipes to site	Y	1

- a) Fill in the tasks and times in the correct places in the network below. (2)

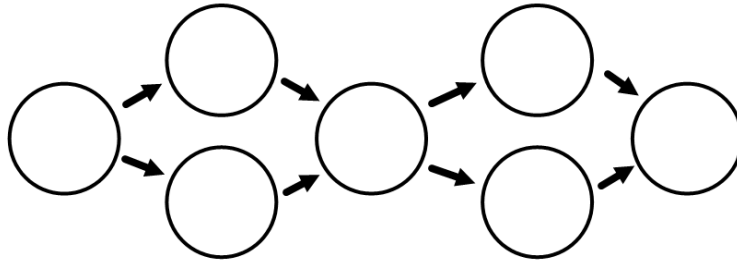

- b) How long will this job take the workmen? (2)

**For further practice on this topic, go to the TeeJay textbook page 175=176**

### S) Time Zones

- 82) Non-calculator New York time is 5 hours behind GMT. When it is 7pm in Britain, it is 2pm in New York.
- At 10am Gordon, who is in New York, phones home to Britain. What time is it in Britain? (1)
  - Los Angeles time is 3 hours behind New York time. From Los Angeles, Fiona needs to phone a colleague in Aberdeen before 6pm GMT. Fiona makes the call at 9:30am, Los Angeles time. Does she meet the 6pm deadline? **Give a reason for your answer.** (4)
- 83) Calculator A plane takes off from Berlin at 2246 and flies 3247km to India at an average speed of 438km/h.
- Calculate the duration of the flight in hours and minutes. (3)
  - Berlin is 3½ hours behind India. Calculate the time in India when the flight lands. (3)
- 84) Non-calculator Leslie is on holiday in Thailand, where the time is 6 hours ahead of GMT.

For her journey back Leslie's plane takes off at 1025 on Wednesday (Thailand time) and the flight lasts 11 hours 42 minutes.

Once the flight has landed, it takes Leslie 6 minutes to get off the plane, 32 minutes to go through immigration, 24 minutes to collect her baggage and 14 minutes to get to her car. She drives home in 1 hour 45 minutes.

She is due to meet her friend at 2100 GMT on Wednesday. Will Leslie be late? Explain your answer. (4)

### T) Tolerance

**Success criteria:**

**Mark 1** – state maximum and minimum

**Mark 2** – use maximum and minimum in the way that the question asks you to

85) Calculator A sculpture is to be made by stacking three blocks of stone. Each block of stone is a cube of sides  $1.2 \text{ metres} \pm 5\text{cm}$ .

- What is the maximum **height** of the entire sculpture in metres? (2)
- What is the minimum **volume** of the stone needed to make the sculpture in  $\text{m}^3$ ? (3)

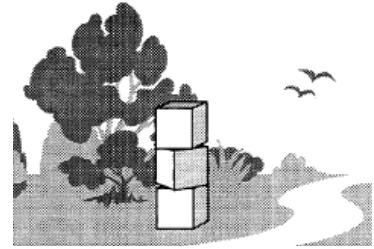

86) Calculator A shoe box is in the shape of a cuboid with sides of length 10cm, 15cm and 30cm. Given that each of these lengths is measured to a tolerance of  $\pm 10\%$  calculate: the maximum and minimum **volume** of the box. (2)

87) Non-calculator The CDT department orders screws of length  $4.2\text{cm} \pm 0.5\text{mm}$ .

- What is the maximum acceptable length of the screw?
- What is the minimum acceptable length of the screw?
- Which of these screws are acceptable? (3)

A:  $41.2\text{mm}$

B:  $42.4\text{mm}$

C:  $42.0\text{mm}$

D:  $41.45\text{mm}$

88) Calculator Packets of cereal go through a quality control process. Packets are rejected if they are not in the range  $500\text{g} \pm 2\%$ .

The weight of eleven packets was counted and recorded as follows:

490g 503g 512g 498g 500g 506g 487g 494g 501g 491g 499g

What **percentage** of packets would be rejected? (4)

89) Non-calculator A piece of wood was cut to be  $2.6\text{m} \pm 5\text{cm}$ .

- What is the shortest length that the piece of wood might be?
- What is the longest length that the piece of wood might be? (2)

90) Non-calculator An artist works with clay. Her studio is supposed to be kept at a temperature of  $70^\circ\text{F} \pm 1.5^\circ\text{F}$ .

The current temperature in the studio is shown on the temperature dial in the picture.

Is the studio at the correct temperature? **Explain your answer.**

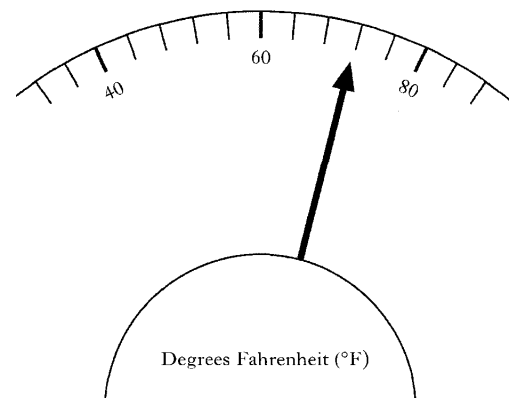

**For further practice on this topic, go to the TeeJay textbook page 112-115**



U) **Gradient**

91) Calculator Blacklight Hill is 210 metres high. A road going up the hill has length 280m.

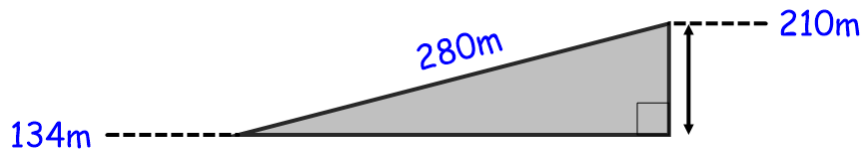

Dylan's car cannot climb roads with a gradient higher than 0.3. Can Dylan's car climb this hill? **Explain your answer.** (4)

92) Calculator A wheelchair ramp is designed to a specification. The specification says that it must have a gradient of  $10\% \pm 5\%$ .

When a prototype is checked it is found to have a run of 1.2 metres and a rise of 17cm. Does the ramp meet the specification? **Explain your answer.** (4)

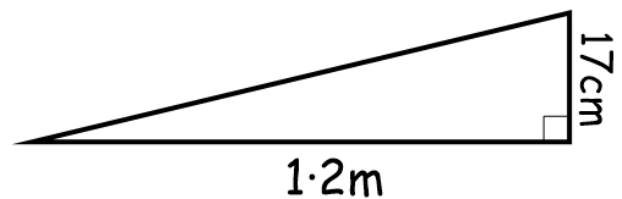

93) Calculator A road drops from a height of 1423 metres to a height of 1376 metres. Given that the road has gradient  $\frac{1}{3}$ , calculate the (sloping) length of the road. (4)

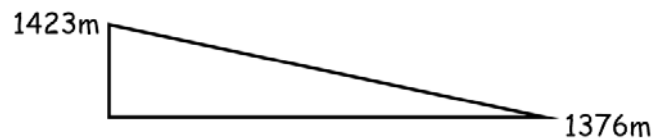

94) Non-calculator A wheelchair ramp has a rise of 50cm and a run of 8m as shown in the diagram on the right.

a) Calculate the gradient of the ramp as a fraction in its simplest form. (2)

b) The law states that wheelchair ramps must have a gradient of less than 1 in 15. Does this ramp break the law? **Explain your answer.**

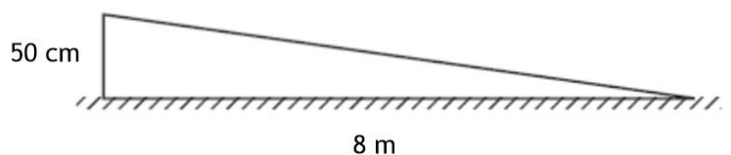

**For further practice on this topic, go to the TeeJay textbook page 151-153**

**V) Volumes**

95) Non-Calculator. Calculate the volume of each shape below. Shape (a) is a sphere, (b) is a cylinder and (c) is a cone. Use  $\pi = 3 \cdot 14$ .

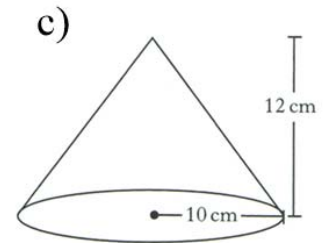
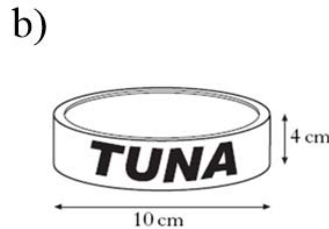
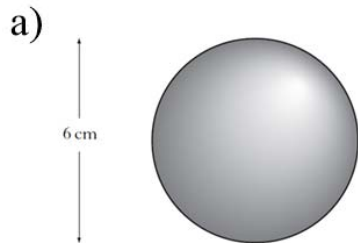

96) Calculator A health food shop produces cod liver oil capsules for its customers. Each capsule is in the shape of a cylinder with hemispherical ends as shown in the diagram.

The total length of the capsule is 23 millimetres and the length of the cylinder is 15 millimetres. Calculate the volume of one capsule, rounded to 3 significant figures. (5)

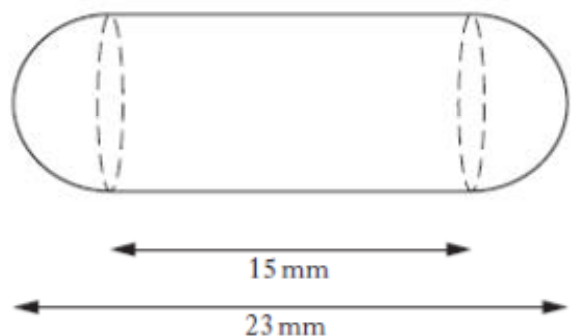

97) Calculator A concrete clock is in the shape of a prism. The cross section of the prism is a symmetrical trapezium with dimensions as shown.

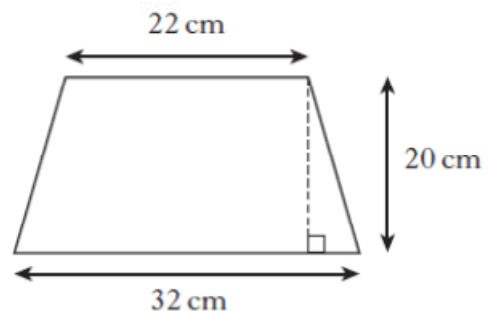
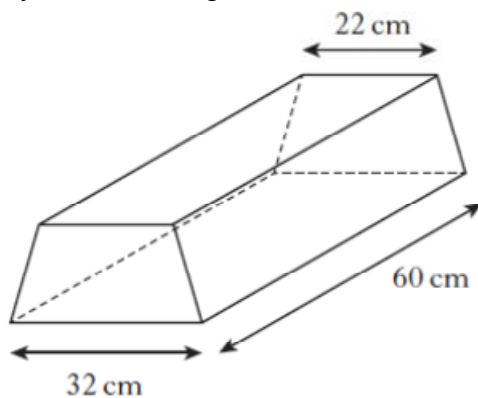

- Calculate the area of the cross section. (2)
- $20\text{cm}^3$  of concrete costs £5.10. Calculate the total cost of the concrete block rounded to two significant figures. (4)

98) Calculator A waste paper bin is in the shape of a large cone with a smaller cone removed. The large cone has radius 14 centimetres and height 22 centimetres. The small cone has radius 8 centimetres. Calculate the volume of the bin. (5)

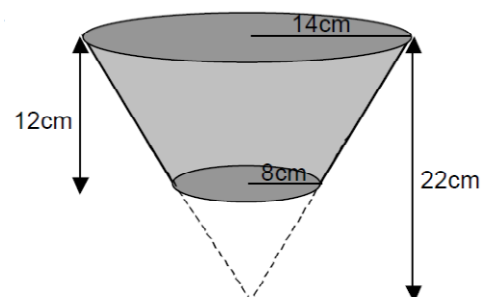

99) Calculator A container for oil is in the shape of a prism. The width of the container is 9 centimetres. The uniform cross section of the container is symmetrical and consists of a rectangle and a triangle as shown.

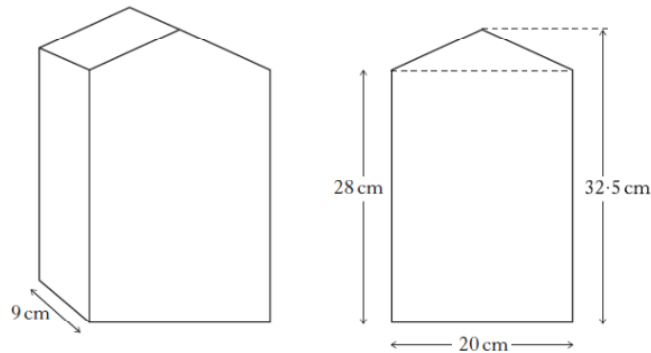

Calculate the volume of the entire container, **correct to the nearest litre**. (4)

100) Calculator A hollow pipe is made out of metal as shown. Find the volume of the metal used to make the pipe rounded to three significant figures. (5)

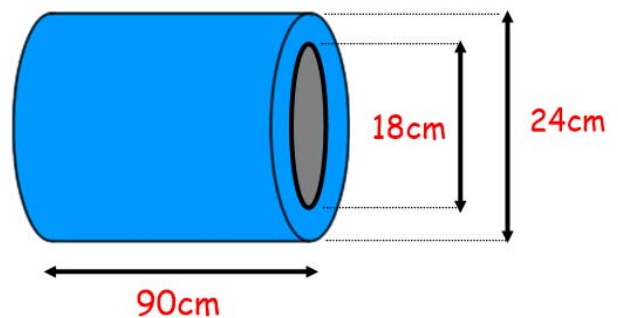

101) Calculator A flower planter is in the shape of a prism. The cross-section is a symmetrical trapezium with dimensions as shown.

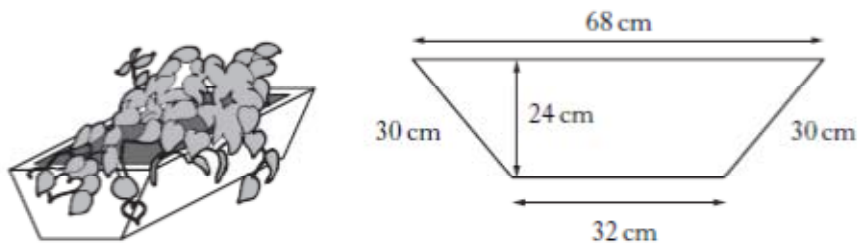

a) Calculate the area of the cross-section of the planter. (3)

b) The volume of the planter is 156 litres. Calculate the length,  $l$  centimetres, of the planter. (2)

c) A smaller planter is made. The ratio of the volume of the larger planter to the volume of the smaller planter is 4:3. What is the volume of the smaller planter? (2)

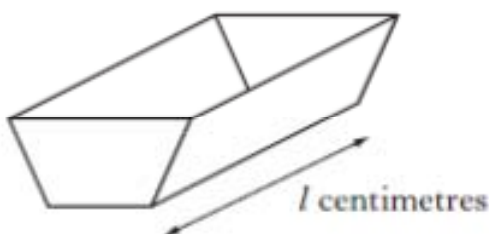

102) Calculator A drinks container is in the shape of a cylinder with radius 20 cm and height 50cm.

- Calculate the volume of the drinks container. Give your answer in cubic centimetres, correct to 2 significant figures. (3)
- The liquid from the cylindrical container can fill 800 cups, in the shape of cones, each of radius 3 centimetres. What will be the height of liquid in each cup rounded to the nearest centimetre? (4)

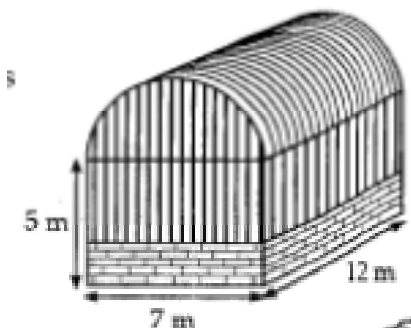
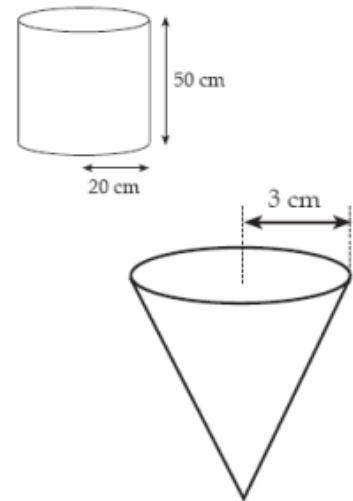

103) Calculator A storage barn is prism, shaped, as shown in the diagram. The cross-section of the storage barn consists of a rectangle measuring 7 metres by 5 metres and a semi-circle of radius 3.5 metres.

Find the volume of the storage barn. Give your answer in cubic metres, correct to 2 significant figures. (4)

104) Calculator Lemonade is to be poured from a two-litre bottle into glasses. Each glass is in the shape of a cylinder of radius 3 centimetres and height 8 centimetres. How many complete glasses can be poured from the bottle, if a 1cm gap is left at the top of each glass? (4)

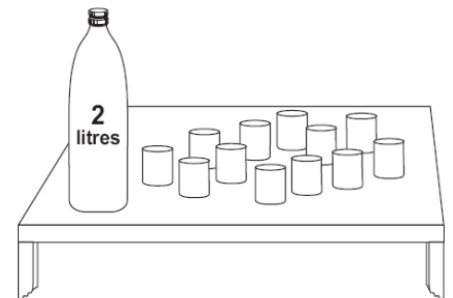

**For further practice on this topic, go to the TeeJay textbook page 184-186**

### W) Area and Circumference

105) Calculator A badge is made out of metal in the shape of a semicircle and a rectangle as shown in the diagram on the right.

The metal costs 8.3p per  $\text{mm}^2$ . Calculate the total cost of the metal for the badge in pounds. (6)

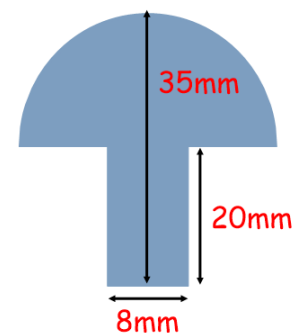

- 106) Calculator A semi-circular window in the school assembly hall is made from three identical panes of glass. During a recent storm one pane of glass was damaged.

Glass can be bought in multiples of  $10\text{cm}^2$ , costing £2.40 per  $10\text{cm}^2$ .

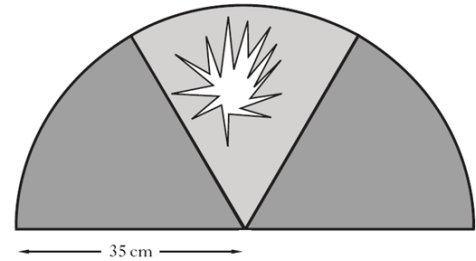

The semi-circle has a radius of 35 cm. Calculate the cost of replacing the damaged pane of glass. (4)

- 107) Calculator A battery operated toy train travels on a circular track. The radius of the circle is 40 centimetres.

In one minute the train travels around the track 8 times. Calculate the speed of the train in metres per second. (5)

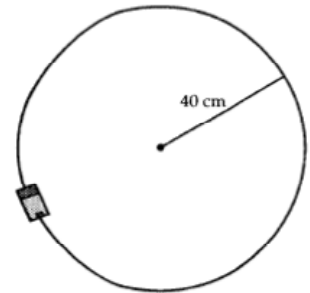

- 108) Calculator A kitchen worktop is in the shape of a rectangle with a quarter circle at one end. The width of the worktop is 600 millimetres and the overall length is 2.8 metres, as shown in the diagram. Calculate the area of the whole worktop in **square metres**. (5)

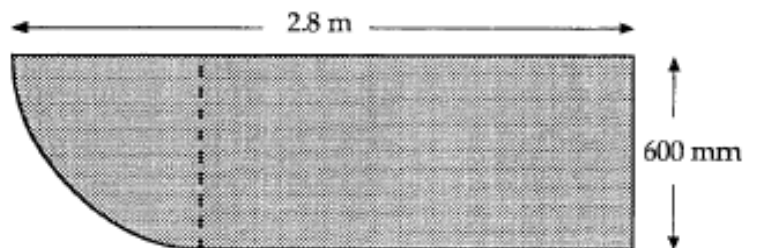

**For further practice on this topic, go to the TeeJay textbook page 161-162**

## X) Pythagoras

- 109) Non-calculator The diagram shows a patio in the shape of two right-angled triangles.

- Calculate the length AB. (3)
- Calculate the area of the patio. (2)
- Another larger patio is made. The ratio of the dimensions of the larger patio to the dimensions of the smaller patio is 5:2. How long is side AB in the larger patio?

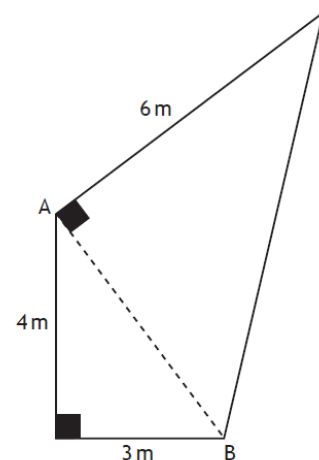

- 110) Non-Calculator A mast is fixed to the corner of a concrete base as shown in the diagram. A wire is fixed from the top of the mast to the opposite corner of the base.

The base is 4m long and 3m wide. The mast is 12m high. How long is the wire? (**Hint:** Pythagoras needs to be used twice)

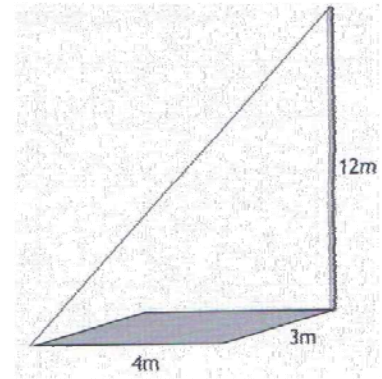

- 111) Calculator A flagpole is supported two thirds of the way up by four steel ropes, each 10 metres long.

The ropes are secured at the four corners of a rectangle measuring 6m by 4m.

The base of the flagpole is in the centre of the rectangle.

Calculate the total height of the flagpole. (5)

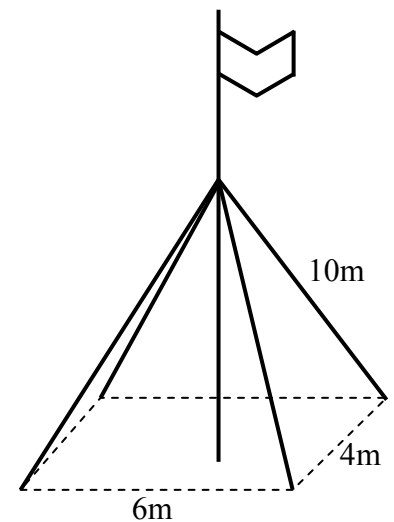

- 112) Calculator The diagram shows a box in the shape of a cuboid. The dimensions of the cuboid are  $AB = 3$  cm,  $AE = 4$  cm,  $BC = 12$  cm.

Gary needs to send an electronic probe of length 16cm through the post.

- Calculate the length of the longest diagonal  $BH$  of the box. (4)
- Can Gary fit the probe along the longest diagonal of the box? Explain your answer. (1)

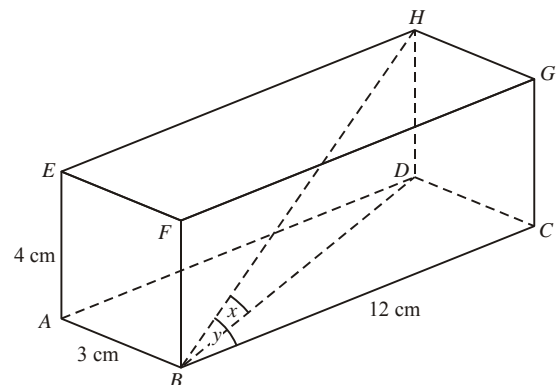

**For further practice on this topic, go to the green textbook pages 159, 162-164, 166-167 (Exercises 8·1B, 8·2A, 8·2B and 8·3A)**

**Y) Speed, Distance and Time**

- 113) Calculator A car travelling at an average speed of 60 km/h takes 2 hours 23 minutes for the journey from Edinburgh to Newcastle. Calculate the distance between the two cities rounded to two significant figures. (3)
- 114) Non-calculator Rhiannon is given a lift to school. She leaves the house at 8:30am and arrives at school at 8:50am. She uses an app on her phone to calculate her average speed for the journey. Her phone displays 6.8 m/s. What distance did she travel? Round your answer to 2 significant figures. (4)
- 115) Non-calculator Susan is driving from Dalkeith to York. The computer in her car tells her that she has done 210 miles at an average speed of 50mph.
- How long has the journey taken in hours and minutes?
  - If Susan left Dalkeith at 17 55, what time did she arrive in York?
- 116) Calculator The world records (min:sec) for the 1500m in athletics are:
- 3 minutes 26.37 seconds for men (Hicham El Guerrouj, Morocco)
  - 3 minutes 50.46 seconds for women (Qu Yunxia, China)
- Calculate the speed of the men's world record in metres per second. (3)
  - Calculate the speed of the women's world record in kilometres per minute. (3)
- 117) Non-calculator Daniel jogs at an average speed of 2.98m/s from 9:40pm until 10:10pm. How far did he jog in total? Give your answer in kilometres. (4)
- 118) Non-calculator A plane flies 2130km at a speed of 300km/h. How long will the journey last in hours and minutes? (4)

**For further practice on this topic, go to the TeeJay textbook page 138-142**

**Z) MIXED TOPICS**

119) Calculator The pie chart on the right shows the votes cast in an election for Birmingham North West.

21 800 people in Birmingham North West are eligible to vote.

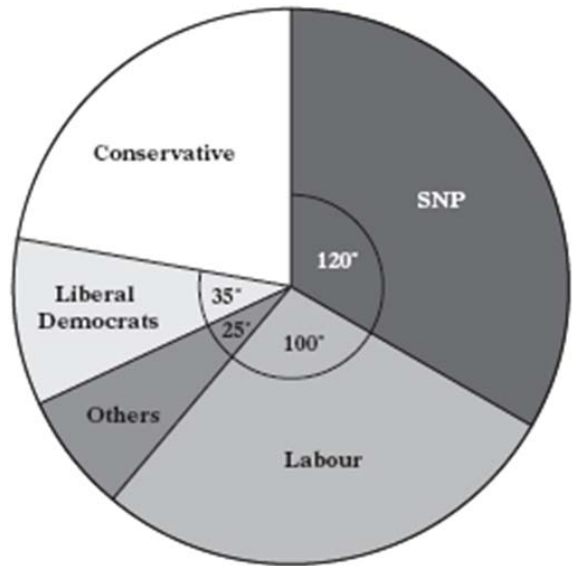

- 62% of people eligible to vote actually voted. How many votes were cast for the Conservatives? (3)
- What is the ratio of votes cast for Labour to votes cast for the Liberal Democrats? Give your answer in its simplest form. (2)
- What percentage of people voted Labour? Give your answer rounded to 1 decimal place. (3)

120) Calculator A mobile phone mast, 18.2 metres high, stands vertically in the centre of a circle. It is supported by a wire rope, 19 metres long, attached to the ground at a point on the circumference of the circle, as shown.

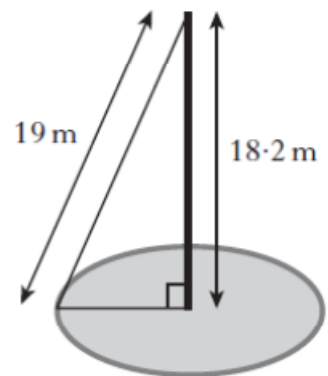

Calculate the circumference of the circle. (4)

121) Calculator The graph on the right shows the number of medals won by Scotland in each Commonwealth Games since 1986.

- How many silver medals did Scotland win in 2002? (1)
- What was the mean number of gold medals won in each games? Round your answer to 2 significant figures. (3)
- What percentage of the total number of medals won by Scotland were gold? (3)
- What is the ratio of bronze medals to silver medals?

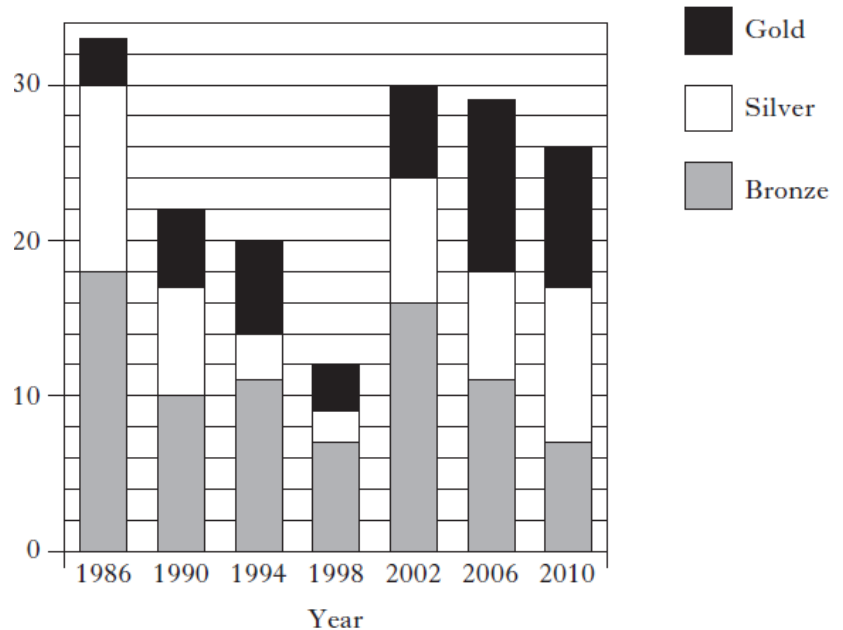

- A gold medal is picked at random. What is the probability it is from 2006? (1)



- 122) Calculator A rectangular shaped picture measuring 610mm by 180mm is placed diagonally in a cuboid box as shown in the diagram.

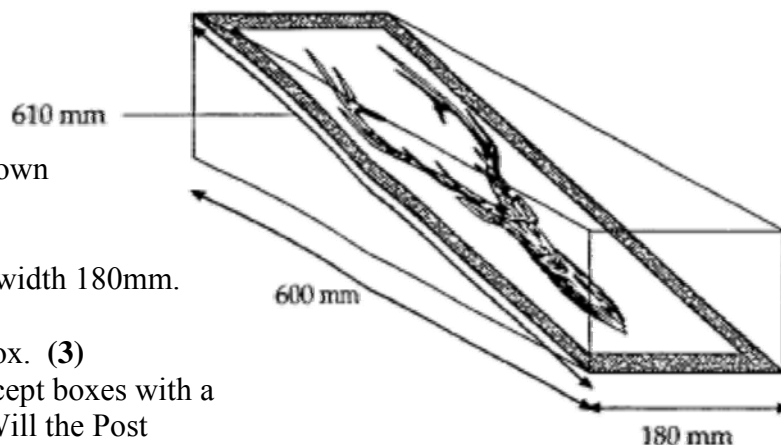

The box has length 600mm and width 180mm.

- a) Calculate the height of the box. (3)  
 b) The Post Office will only accept boxes with a volume less than 11 litres. Will the Post Office allow this box to be posted? **Explain your answer.** (3)
- 123) Calculator The tables below show the costs of the ingredients for a meal at a restaurant.

- a) What percentage of the total cost of the meal was for the starter?  
 b) The three-course meal costs £22. If twenty people order the meal, does the restaurant make a profit? **Explain your answer.**  
 c) What is the ratio of the cost of the vegetables to the cost of strawberries? Simplify your answer.  
 d) It took 2½ hours to cook the meals for twenty people. Next week, the restaurant wants to make meals for thirty people. If they work at the same rate, how long will it take them?

Course	Ingredients
Starter	£54 prawns £11.50 vegetables £5.50 sauce
Main Course	£98 chicken £42.50 vegetables
Dessert	£12 strawberries £5.90 cream

- 124) Calculator Mr Robson earns £23400 a year.  
 His annual tax allowances total £10,200 and he pays tax at a rate of 20%.  
 He pays National Insurance at a rate of 9.5% on annual gross income over £8,450.  
 He pays 6% of his total gross income into his pension fund.

- a) Calculate Mr Robson's **monthly** net pay.  
 b) Complete the monthly income and expenditure table below.

**Mr Robson's Monthly Budget**

	<i>Income</i>	<i>Outgoings</i>
Wages		
Investments	£150	
Food		£230
Electricity		£70
Bill		£350
Phone		£24.50
Car		£124
Entertainment		£55
<b>Total</b>		

- c) Does Mr Robson have a surplus or a deficit each month, and how much is it?  
 d) Mr Robson wants to buy a second hand car costing £3500. Every week he saves all his surplus money into a savings account. How many months will it take him to save the money for the car?

- 125) Calculator Towns P, Q and R are connected by straight railway lines.

Town R is 30km away from P on a bearing of  $125^\circ$ .

Town Q is on a bearing of  $040^\circ$  from P and  $340^\circ$  from R.

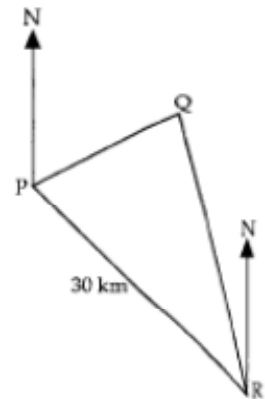

- (a) Choose an appropriate scale and construct a scale drawing of the railway lines between the three towns. (3)

The railway company have closed the line to lay new tracks for the weekend from P to Q and then Q to R. The track laying machine travels at a steady speed of  $3.2 \text{ km/h}$ .

The railway must reopen by 0600 on Monday morning at the latest.

- b) Use your scale drawing to calculate the **latest** time that the railway company must begin to lay the tracks. (5)

- 126) Calculator A football is in the shape of a sphere with diameter  $11 \text{ cm} \pm 3 \text{ mm}$ . What is the difference between the maximum and minimum volumes of the football? (5)

- 127) Calculator Cones with a diameter of 8cm and a sloping height of 14cm as shown in the diagram are going to be made out of metal.

How many complete cones can be made from  $2000 \text{ cm}^3$  of metal? (4)

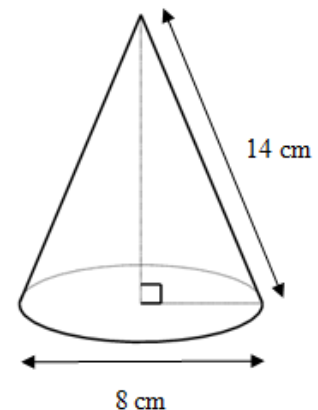

- 128) Calculator

- (a) Convert  $61.2 \text{ km/h}$  into metres per second. (3)  
 (b) The diagram below shows a racing track in the shape of two right-angled triangles.

Paul travels the distance marked  $x$  in 55 seconds at a speed of  $61.2 \text{ km/h}$ .

Calculate the length  $y$ . Give your answer correct to 2 significant figures. (5)

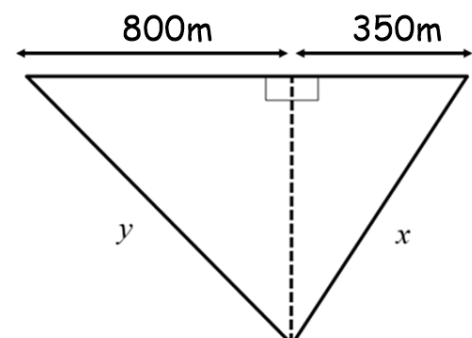

- 129) Non-calculator A concrete ramp is being built for a factory. The uniform cross-section of the ramp consists of a right-angled triangle and a rectangle as shaded in the diagram.

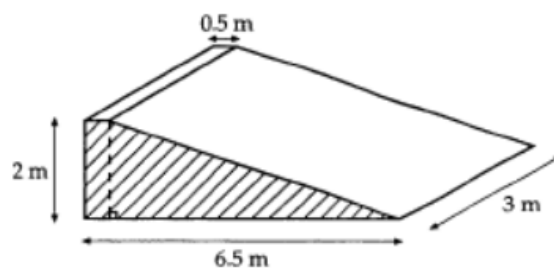

- a) Calculate the gradient of the sloping part of the ramp as a fraction in its simplest form. (2)
- b) The manager of the company says that the ramp should have a gradient of  $\frac{3}{24}$ , so the height of the ramp is lowered to match. All other lengths remain the same. Calculate the total volume of concrete required to make this lower ramp. (5)

- 130) Calculator The stem and leaf diagram shows the number of minutes on average spent on homework per night by a group of first year pupils.

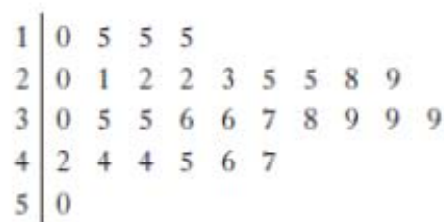

$n = 30$

1 | 0 represents 10 minutes

- (a) What percentage of first-year pupils spent more than 40 minutes per night on homework? (1)
- (b) Using the above data find:
1. The median and quartiles (3)
  2. The inter-quartile range (1)
- (c) Draw a boxplot to illustrate this data. (2)
- (d) A group of fourth year pupils was surveyed to find out how many minutes on average they spent on homework per night. The boxplot below was drawn for this data. Write two comments comparing the homework for first years and the homework for fourth years. (2)

*Show your sentences to a teacher so they can tell you whether your sentences would have been awarded the marks.*

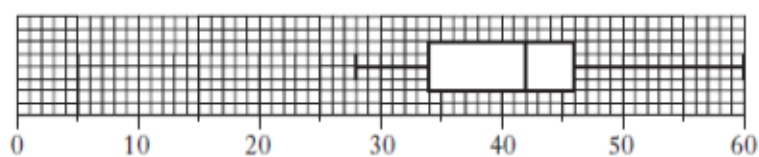

- 131) Calculator A tin of beans is in the shape of a cylinder with diameter 7.3cm. The tin holds 500cm<sup>3</sup> of beans and has a gap of 10cm<sup>3</sup> at the top.

- a) Calculate the height of the tin. (3)
- b) The tins are packed into cuboid boxes measuring 50cm by 40cm by 90cm. What is the largest number of tins that can be packed into one box? (4)

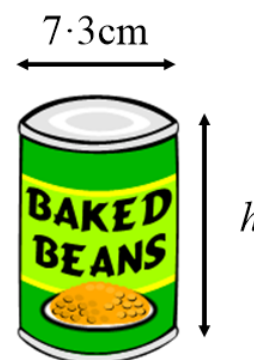

The company have 65 000 tins of beans to be sent out to supermarkets. One lorry can hold 75 boxes of beans.

- c) How many lorries are needed to transport all the boxes of beans? (3)